

PRODUCT FAMILY DATASHEET

HALOPAR 20 GU10

Halogen lamps with parabolic reflector PAR20, with GU10 base



AREAS OF APPLICATION

- General illumination
- Shops
- Restaurants, hotels and similar prestigious applications

PRODUCT BENEFITS

- Brilliant accent light
- With whole glass reflector for brilliant lighting effects
- Approved for use in open luminaires (to IEC 60598-1)
- No transformer required
- UV filter
- Robust filament design thanks to innovative, unique bulb pinch technology
- Complies with IEC 60432-2 thanks to integrated fuse function
- Contains no mercury

PRODUCT FEATURES

- Average life: 2,000 h
- 100 % dimmable
- Color rendering index R_a : 100
- Color temperature: 2,800 K

TECHNICAL DATA

Product description	Electrical data				Photometrical data				Light technical data		
	Nominal wattage	Nominal voltage	Rated wattage	Power factor λ	Nominal useful luminous flux 90°	Color temperature	Color rendering index Ra	Lumen main.fact.at end of nom.life time	Beam angle	Starting time	Warm-up time (60 %)
HALOPAR 20 75 W 230 V 30° GU10 ¹⁾	75.00 W	230 V	75.00 W	1.00	520 lm	2800 K	100	0.75	30 °	0.0 s	0.00 s

Product description	Dimensions & weight		Lifespan			Additional product data			Capabilities
	Diameter	Overall length	Nominal lamp life time	Rated lamp life time	Number of switching cycles	Base (standard designation)	Mercury content	Mercury-free	Burning position
HALOPAR 20 75 W 230 V 30° GU10 ¹⁾	64.0 mm	62.0 mm	2000 h	2000 h	50000	GU10	0.0 mg	Yes	Any

Product description	Dimmable	Certificates & standards		Country-specific categorizations
		Energy efficiency class	Energy consumption	ILCOS
HALOPAR 20 75 W 230 V 30° GU10 ¹⁾	Yes	D	75 kWh/1000h	HAGS/UB-75-230-GU10-64/30

¹⁾ Not suitable for outdoor use or damp conditions/Banned from 1.9.2016 as per EU phase-out plan

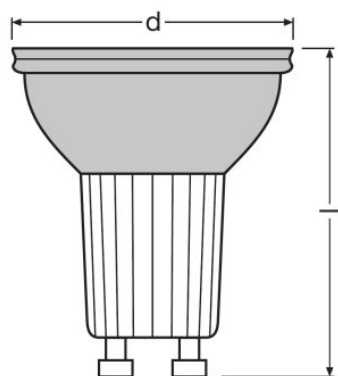

HALOPAR 20 75 W 230 V 30° GU10

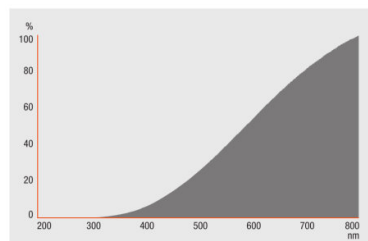

HALOPAR 20 75 W 230 V 30° GU10

APPLICATION ADVICE

For more detailed application information and graphics please see product datasheet.

LOGISTICAL DATA

Product code	Product description	Packaging unit (Pieces/Unit)	Dimensions (length x width x height)	Volume	Gross weight
4050300856971	HALOPAR 20 75 W 230 V 30° GU10	Shipping carton box 20	303 mm x 165 mm x 132 mm	6.60 dm ³	1422.60 g

The mentioned product code describes the smallest quantity unit which can be ordered. One shipping unit can contain one or more single products. When placing an order, for the quantity please enter single or multiples of a shipping unit.

DISCLAIMER

Subject to change without notice. Errors and omission excepted. Always make sure to use the most recent release.