

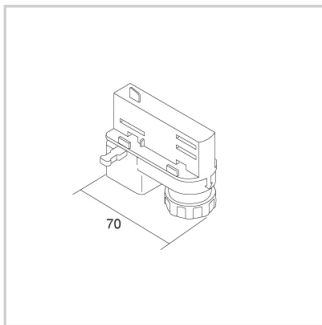

MECHANICAL/ELECTRICAL ADAPTER



Product code	Colour
--------------	--------

7601-00-W20/30/31	100
-------------------	-----

General Specifications

Description	: Electro/mechanical adapter 6A, load 5 Kg.
Indoor/outdoor lights	: Indoor

Physical Specifications

Packing quantity	: 10
Mechanical load (Kg)	: 5

Electrical Specifications

Current (A)	: 6
Glow wire (°C)	: 850

Weight and Dimensions

Length (mm)	: 70
-------------	------

Pictures and Applications

