

Wide range of switches, energy sockets (compliant with national and international standards), data sockets, devices for the management of climate control, comfort, technical alarms signalling, emergency lighting. The Chorus modular devices are available in four colors, glossy white, satin black, painted titanium and glossy ivory and in different modularities, 1/2, 1, 2 and 3 modules. Thanks to the frame supports for rectangular, square and round boxes, the devices allow you to create endless combinations with the range of Chorus plates.

Category	Dual amperage interlocked socket-outlet	Description	2P+E - 16A
Colour	White	Type	Interlocked
Voltage	230V ac	Standard	English
Wiring terminals	With screw	Protection	MCB
Socket-out type	P17-P11	Miniature circuit breakers	1P+N 16A
Breaking capacity	3 kA	Standard	IEC 60884-1; EN 60898-1
Resistance at test voltage	2000 V at 50 Hz for 1 minute	Insulation resistance	> 5 MOhm
Breaking capacity	1.25 In (100 position changes)	Prolonged operation (no.of position changes)	10.000 at In 250 V ac cosØ=0,8
Thermo-pressure with ball	125 °C	Glow Wire Test	850 °C
Terminal grip on cable traction	> 50 N	Terminal tightening capacity flexible cables (mm2)	min. 0,75 - max. 2x4
Terminal tightening capacity rigid cables (mm2)	min. 0,5 - max. 2x2,5	No. Chorus modules	2
Electrocod	0131		

### DIMENSIONAL

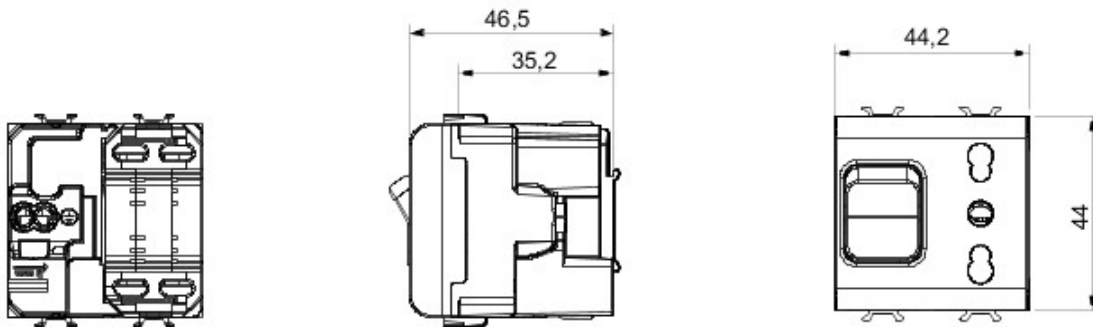

### TECHNICAL SYMBOLOGY



125 °C



850 °C

### STANDARDS/APPROVALS



GEWISS S.p.A. Via A. Volta, 1  
24069 Cenate Sotto - Bergamo - Italy  
tel. +39 035 94 61 11 fax +39 035 94 69 09

www.gewiss.com  
sat@gewiss.com  
Last update 09/08/2018

Data, measures, designs and pictures are shown only as informativ purposes, and could be changed without previous notice